

PRE-TERMINATED F2 FIBRE OPTIC CONTACT

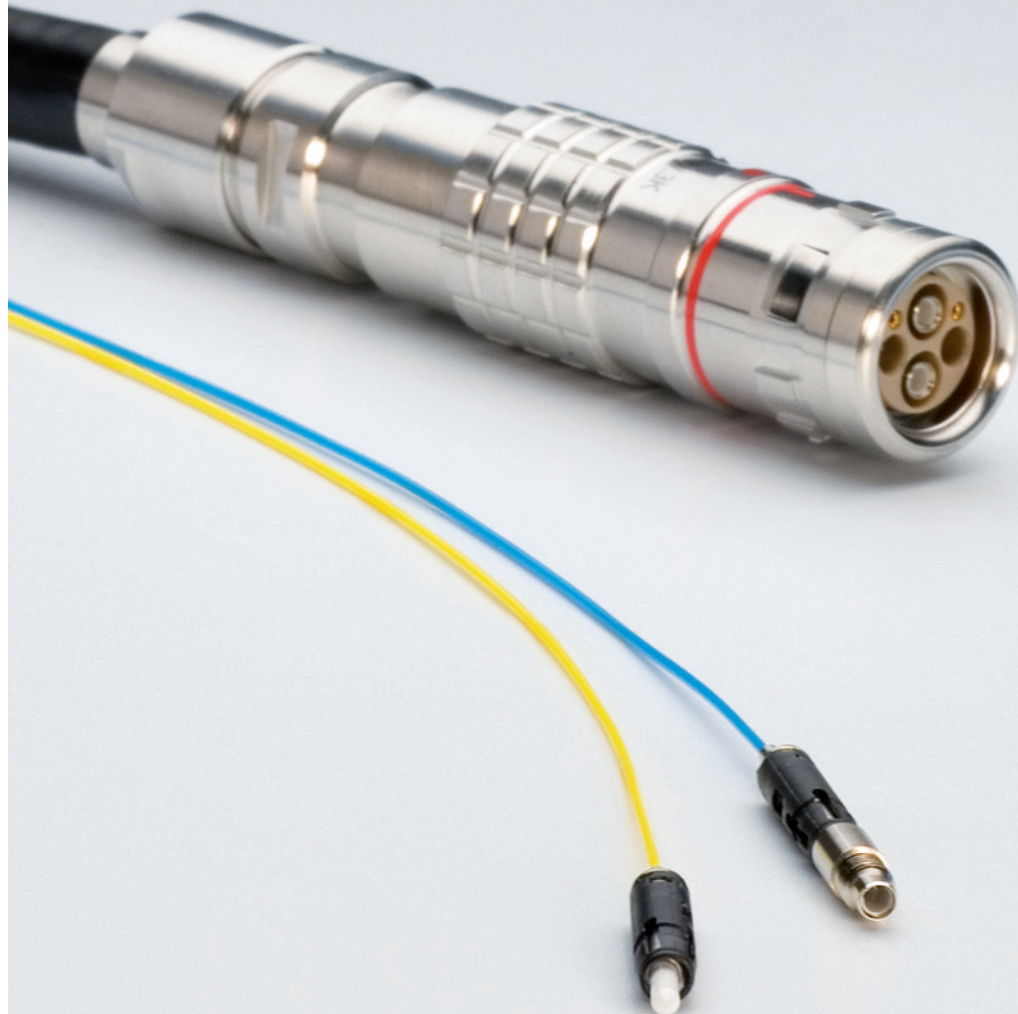

Pre-terminated F2 fibre optic contacts - offering a quick and easy field solution

The pre-terminated contact provides the user with a contact that can be terminated without the use of epoxy, or polishing. The F2 pre-terminated fibre optic contact is designed as repair solution but may also be used for indoor fixed installations. It is intended for use in situations where it is critical that a cable be repaired quickly. The pre-terminated contacts enable simple and rapid on-site-terminations for SMPTE-311M cables.

The design eliminates the need of polish fibre-optic elements as well as preparing and using special epoxies for the fibre assembly.

The F2 pre terminated contact is entirely compatible with, and is designed for use with, the LEMO 3K.93C Series. It also fits into any connector where the standard LEMO F2 contact is used.



The F2 pre terminated contact is designed for fitting into single 0K series, multifibre connectors or mixed optical /electrical connectors from 2B to 5B, 2K to 5K Series.

Its main features are:

- easy and fast assembly
- no polishing - no epoxy
- easy identification with black PEEK
- no need for costly and bulky equipment
- simple cleaning process

Technical Characteristics

Characteristics	Value	Standard
Mating durability	10000 cycles	IEC 61300-02-02
Damp heat steady state	up to 95% at 60° C	IEC 61300-02-19
High temperature	+60° C	IEC 61300-02-18
Low temperature	-20° C	IEC 61300-02-17
Impact (Method A)	1 m onto concrete floor	IEC 61300-02-12
Shock (3 cycles in 2 directions)	100g, 10-50 ms; 20g 6-9 ms	IEC 61300-02-09

Optical

Characteristics	Value	Standard	Method
Average insertion loss fibre 9/125 µm	0.50 dB	IEC 61300-03-04	Insertion Method B
Return loss fibre 9/125 µm (UPC)	≥ 45 dB	IEC 61300-03-06	Branching Device Met.

Part Section Showing Internal Components

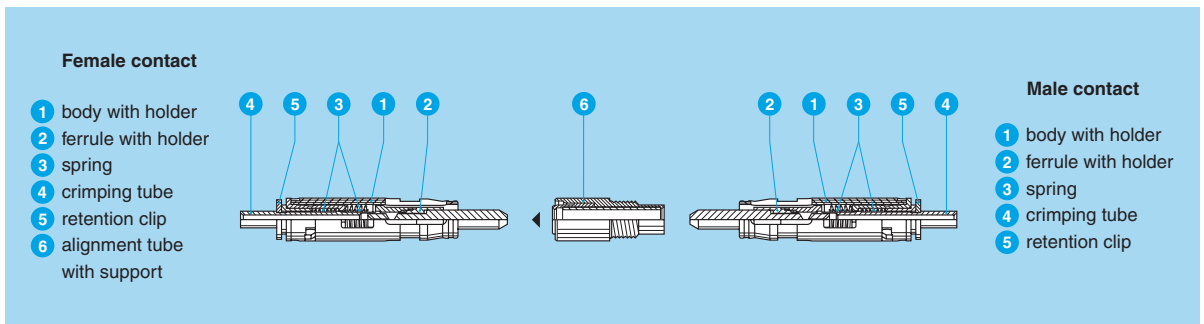

Models

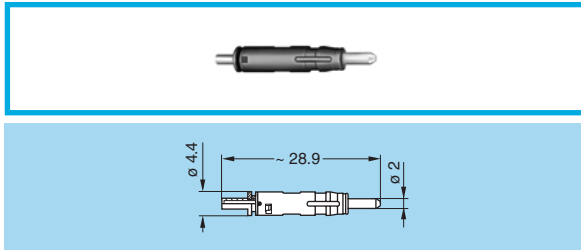

FFT.F2 Pre-terminated F2 male fibre optic contact

Part Number	Fibre type	Fibre coating structure
FFT.F2.BA2.LCE10	Singlemode 9/125	Buffer coated ø 0.25 to 1.1 mm

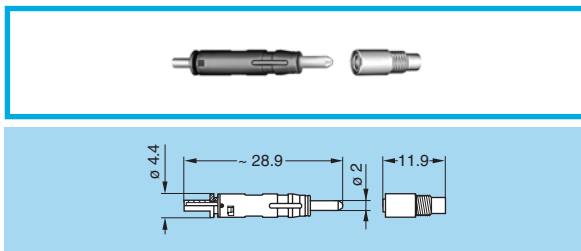

PST.F2 Pre-terminated F2 female fibre optic contact

Part Number	Fibre type	Fibre coating structure
PST.F2.BA2.LCE10	Singlemode 9/125	Buffer coated ø 0.25 to 1.1 mm

Note: all dimensions are in millimetre.

Tooling for field termination (3K.93C Series)

Part Number	Description	Part Number	Description
DCE.91.093.BVC	Positioner for signal ¹⁾ (male), 0.9 mm	DPD.99.010.5K	Crimping tool for screen crimping on FUW and PUW
DCE.91.093.BVM	Positioner for signal ¹⁾ (female), 0.9 mm	DCP91.023.TN	Spanner for tightening collet nut
DCE.91.133.BVCW	Positioner for power ²⁾ (male and female), 1.3 mm	WST.OU.110.20PN	Fibre cleaver for pre-terminated contact ³⁾
DPC.91.701.V	Manual crimping tool (signal contacts ϕ 0.9)	WST.PN.102.3CR	Primary coat stripper for pre-terminated contact ³⁾
DPC.91.101.A	Manual crimping tool (power contacts ϕ 1.3)	DPW.99.PZ6.HEX	Manual crimping tool for pre-terminated contact ³⁾

Note: 1) These positioners are suitable for use with both manual and pneumatic crimping tools according to the MIL-C-22520/7-01 standard.
 2) These turrets can be used with manual crimping tool according to MIL-C-22520/1-01 standard. Power contacts are special with an oversized crimp barrel.
 3) For specific use with the pre-terminated contacts FFT.F2.BA2.LCE10 or PST.F2.BA2.LCE10.

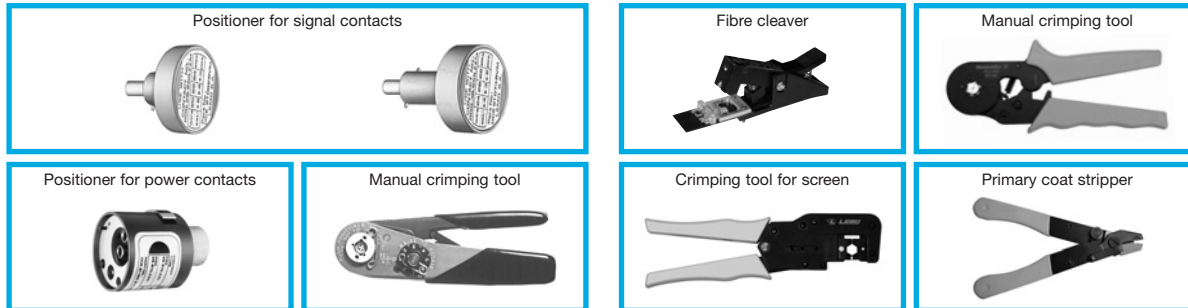

Maintenance tools

DCS.91.F23.LA Cleaning tool F2 contact

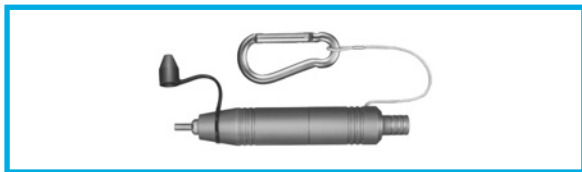

Used for maintenance cleaning. The tool is made with a sponge alcohol reservoir (supplied empty). 16 dry cotton buds are included. The threaded end allows extraction/reinstallation of the F2 contact alignment device.

WST.KI.125.34 Cleaning kit F2 contact



Fibre optic cleaning kit of 2 cotton buds, 1 dry and 1 being soaked in IPA (Isopropyl Alcohol) used for cleaning the fibre optic contacts.

DCS.F2.035.PN Alignment device tool



Simple tool with two threaded end for installation/extraction of the F2 contact alignment device. For use with WST.KI.125.34 kit above.

DCT.F2.125.PA Fibre Optic ferrule cleaner



This cleaning tool comes with a bush for different cleaning configurations. More than 500 cleaning per cleaner. This cleaner is for on-site purposes only and should not replace regular maintenance cleaning with cotton buds and alcohol.

WST.FB.CI1.000F2 Video inspection viewer



A portable fibre optic viewer for F2 contact consisting of handset probe, LCD display, ferrule tips for LEMO contacts, USB capture device & software & AC power supply all in a rugged case.

WST.LA.JDS.UF2 Visible laser source



Provides easy checking of fibre position within the fibre contact during assembly



Accessories

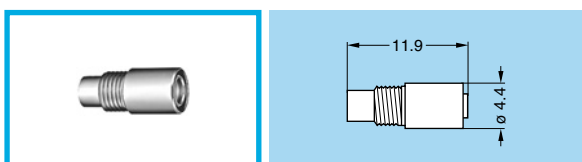

PSS Alignment device for F2 fibre optic contact

Part Number
PSS.F2.290.NZZ

Note: Alignment device should be ordered as replacement item.

●UW Parts for field repair with pre-terminated F2 contact



Part Number (Repair kit for FUW plug)	Content part number	Description	Quantity
FUW.3K.93C.ZLMC96W	EGW.3K.444.EL	Insulator for plug	1
	EGG.3B.660.ZZM	Contact for signal	2
	FGW.3K.565.ZZC	Contact for power	2
	PST.F2.BA2.LCE10	Pre-terminated F2 contact	2
	FGW.3K.146.ZZA	Anchor with screws	1
	FFS.3K.130.LNV	Earthing body with o-ring	1
	FFS.3K.160.DN	Crimp ring	1
	GDA.99.140.100VK	O-ring for backshell	1
GMA.30.025.CN	Protection sleeve	2	

Part Number (Repair kit for PUW socket/receptacle)	Content part number	Description	Quantity
PUW.3K.93C.ZLCC96W	FGW.3K.344.EL	Insulator for socket (recep.)	1
	FGG.3B.560.ZZC	Contact for signal	2
	EGW.3K.666.ZZM	Contact for power	2
	FFT.F2.BA2.LCE10	Pre-terminated F2 contact	2
	FGW.3K.146.ZZA	Anchor with screws	1
	FFS.3K.130.LNV	Earthing body with o-ring	1
	FFS.3K.160.DN	Crimp ring	1
	GDA.99.140.100VK	O-ring for backshell	1
GMA.30.025.CN	Protection sleeve	2	

Overview of pre-terminated F2 assembly instructions

The pre-terminated F2 contact is designed for termination on \varnothing 9.2 mm or 16 mm cable camera containing 900 μ m buffered fibres.

- 1) Remove the cable outer jacket, fold back the earthing braid along the cable, ensure that the electrical conductors are folded back along the cable. Do not to fold back the blue and yellow optical fibres.
- 2) Remove the fibre strain jacket. Remove the remaining buffer coating and finally remove the primary coating using the primary coat stripper (WST.PN.102.3CR).
Clean the fibre using the cotton buds provided in the cleaning kit F2 contact (WDT.KI.125.34)

- 3) Carefully cleave the fibre using the fibre cleaver (WST.OU.110.20PN). Patch the pre-terminated contact onto the ferrule making sure that the visible laser source can be seen from the end of the ferrule using the visible laser source (WST.LA.JDS.UF2).
- 4) Crimp the pre-terminated contact using the manual crimping tool (DPW.99.PZ6.HEX). Remove the retention clips (back clips) of the pre-terminated contact. Assemble the electrical contacts using the manual crimping tool (DPC.91.701.A or DPC.91.101.A) and the electrical contact positioners (DCE.91.093.BVC, DCE.91.093.BVM or DCE.91.133.BVCW). Further assembly instruction is similar to the standard F2 fibre optic contact. Please consult the detailed pre-terminated F2 assembly instruction that can be obtained at LEMO subsidiaries.

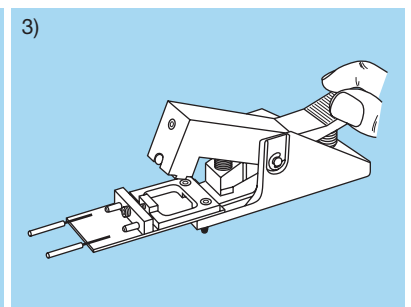
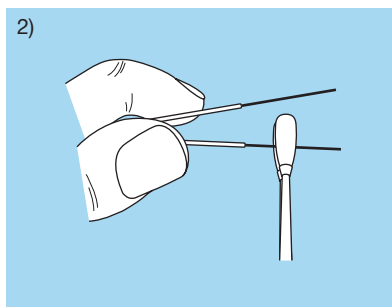
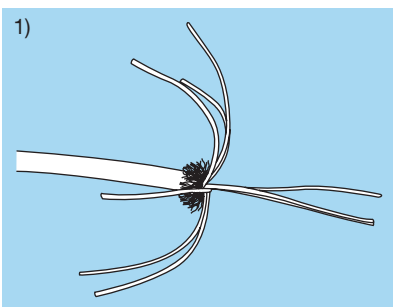

LEMO HEADQUARTERS
 SWITZERLAND
 LEMO SA
 Chemin des Champs-Courbes 28 - P.O. Box 194 - CH-1024 Ecublens
 Tél. (+41 21) 695 16 00 - Fax (+41 21) 695 16 02 - e-mail: info@lemo.com